

Business Impact Analysis: Methods and Techniques that Work!

The Webinar will begin shortly!



Business Impact Analysis: Methods and Techniques that Work!

The Webinar will begin in 2 minutes!



Business Impact Analysis: Methods and Techniques that Work!

The Webinar will begin in 1 minute!



Business Impact Analysis: Methods and Techniques that Work!

Welcome!



Agenda

- Introduce our hosts and sponsors
- Meeting logistics
- Introduce our panelists
 - Kathleen Lucey from EMC – “Getting Ready”
 - Mark Carroll from BU – “Running a Successful BIA”
 - Don Byrne North River Solutions – “Using the Information”
- Begin the presentations
- Questions from the attendees

Welcome to ACP

2010 Message from BAO on Board Election for 2011



The **Nominating Committee of the National ACP** is getting ready to seek nominations for qualified individuals to serve on the National Board. Terms are for 2 years.

To be considered for nomination, the individual must:

1. Be an individual member in good standing with dues current for the year, and
2. Served on the **Executive Committee** of a local chapter for not less than 1 year (President, Secretary or Treasurer) or,
3. Served in a **Director** position of a local chapter for not less than 2 years.

Important! Elected Board members should expect to spend between 8 and 12 hours per month on ACP related business.

Nominations will be accepted until July 23, 2010. [Click here for 2011 Corporate Board Nomination Form](#) (This may load slowly, be patient.)

!! Important PS Prep Program Webinar for YOU and It's Not Too Late to register !!

ACP is committed to providing our membership with useful information on relevant subjects. As part of this commitment, ACP will be sponsoring a series of educational webinars. The first of these focuses on career opportunities that might arise from the PS-Prep Program - Career Options and the PS Prep Program. This webinar will take place on July 27, 2010 at 11:00 AM (Eastern Daylight Savings Time).

This webinar will be recorded and a link to the recorded session will be available on this website shortly after the presentation.

For more information or to register [click here...](#)

Looking for a Chapter?



ACP has over 2,760 active members in **NOW 43 CHAPTERS** across the United States.

If you don't find a local Chapter in or near your city and would be interested in helping to develop a Chapter in your area, please email your interest to our Director of Chapter Services.

[Click here for email address...](#)

Message from the CEO: Chapters are a very important link between the member and the organization. In fact, chapters provide the conduit through which many of ACP benefits are made available.

ACP provides a forum for the exchange of experiences and information through a network of local chapters. Chapters offer members convenient, low-cost educational programs and many other benefits.

The ACP Corporate Board stands ready to assist in the development and operation of a chapter. The primary liaison between the chapter and the Board is the Director of Chapter Services. We are committed to our mission to provide a powerful network for the advancement of the industry and the development of business continuity professionals.

I wish you every success in your endeavors.

Sincerely,

Hike Thomas
CEO

[Frequently Asked Questions About Starting a Chapter](#)



National Preparedness Month

September 2010

September is National Preparedness Month! We are now just two months away. The National Preparedness Month is sponsored by the Ready Campaign in partnership with Citizen Corps and the Ad Council. The NPM is designed to encourage Americans to take simple steps to prepare for emergencies in their homes, businesses, and communities. To find out more information, click on the link below.

<http://www.ready.gov/america/npm10/index.html>

As an Officer or Director of an ACP Chapter if you haven't signed up yet, click on the link below. Let's demonstrate the commitment of ACP.

<http://www.ready.educouncil.org>

View Our Sponsors



Speakers Bureau

Looking for a speaker for your next meeting?



Visit Our Store



Web Site Updates

Home Page

07/19/2010 - Updated Sponsor Banner with FARECH, logo.

07/15/2010 - Added webinar announcement for PS Prep and career options. Added CIP Congress event.

About / Value Proposition

07/07/2010 - Renamed Mission Page to Value Proposition and added new content.

Knowledge / BCP 101

07/02/2010 - Modified information for ISMS and updated the links.

Knowledge / PS Prep

07/02/2010 - Renamed page from Emerging Topics to PS Prep. Posted updates through July 1st.

Sponsors

07/19/2010 - Updated with FARECH, Bronze sponsorship information.

Members Only

07/15/2010 - Updated special offers page for CIP Congress.

07/01/2010 - Updated the Board's Committee structure with ad-Large-Director Open Position.

Members Only / Job Opportunities

07/01/2010 - updated with new jobs, updated links for job boards, updated links for ISMS materials.

Chapter Board Library

07/04/2010 - Major updates!

www.continuitycompliance.org

Enter keywords....

 SEARCH



CONTINUITY COMPLIANCE

Your Business Continuity Lifeline



HOME EVENTS PS PREP BUSINESS CONTINUITY SECURITY FIND A CONSULTANT TOOLS & RESOURCES FIRST TIMERS CONTACT US



JOIN our next
"Business Impact Analysis" webinar
AUGUST 24

[click here for more info](#)

Newsworthy

-  RISK MANAGEMENT AND WORKPLACE VIOLENCE PREVENTION PROGRAMS
-  Business Impact Analysis Webinar: Methods and Techniques that Work!
-  Business Continuity and Benchmarking Professional Practices
-  Cyber Security: Internet Protocol version 6 (IPv6)
-  E-Discovery 2010 Socha/Gelbmann Survey Discussion



VIEW the
MUST SEE
PS PREP webinar
[CLICK HERE](#)
to watch now.



COMMUNITY
TOOLBOX

[find out more...](#)



COMMUNITY
EVENTS

[find out more...](#)

[www. NorthRiverSolutions.com](http://www.NorthRiverSolutions.com)



The Architects of Resiliency

www.metrix411.com



***The Assessment
and
Information Management
Company***

Use the *Instant Message* feature to submit questions for discussion by the panelists.

The screenshot displays the GoToWebinar control panel. At the top, it shows 'ON AIR - Showing Screen' with buttons for 'Show My Screen', 'Stop Showing Screen', 'Give Keyboard & Mouse', and 'Change Presenter'. Below this is a 'Dashboard' section with a timer at 26:35 (out of 33:45), attendance at 743/1000, and 84% attentive. The 'Audience View' section shows 743 attendees and a list of names including Adam Williams, Allison Jones, Alex Anderson, and Brad Clemens. The 'Audio' section is set to 'Use Mic & Speakers'. The 'Polls' section shows 2/3 polls. The 'Questions' section is expanded, showing a list of questions and answers:

- Q: Which of the two do you recommend?
- Audience Question
- Q: Do you think this applies to direct sales?
- A: Yes. The technique works very well for direct sales situations.
- Be sure to go to our Web site for details.
- Q: Can you send me more information?
- A: Absolutely.

At the bottom, there is a chat input field and a 'Send' button. The webinar title is 'Ten Ways to Increase Sales' with ID 626-343-443.

3 Follow-On Activities

1. All questions listed at www.continuitycompliance.org
2. This session is recorded for playback
3. A Linked-In group entitled "ACP Edu. Webinar Series Q and A Forum" has been set up. All questions will from this session will be posted on this group for further discussion.

Consulting & IT Services

Transforming information into business results

Accelerate the strategic value and impact of information throughout your enterprise. Leverage EMC expertise to lower costs and risk, ensure optimal performance and business agility, and create greater customer value and new business opportunities.

Why EMC 



United Natural Food, Inc.

Discover how UNFI worked with EMC Consulting to create a consolidated state-of-the-art data center and a recovery hot site that delivers the level of service efficiently and sustainably to all areas of the business within

Read the article 

Browse Service Offerings By:

CONSULTING

IT SERVICES

MANAGED SERVICES



Accelerate Business Value

Information is one of your organization's most valuable assets. Unleash its power for optimal efficiency and maximum value with expert assistance from EMC Consulting.

Learn more about EMC Consulting 

Our Services & Expertise:

Application Consulting

Create intuitive digital experiences and use information to collaborate, make decisions, and automate processes.

Business Consulting

Drive product leadership, differentiated customer experience, and operational excellence.

Industry Consulting

Leverage our deep industry expertise and broad technology competencies to achieve market leadership.

Infrastructure Consulting

Transform infrastructure and operations into IT services that support business growth and change.

Private Cloud & Virtualization Consulting

Deliver business agility and IT flexibility and efficiency at enterprise scale.

Boston University Distance Education

[Prospective Students](#)
[Current Students](#)
[Programs](#)
[Schedule](#)
[Registration](#)
[Student Services](#)

Undergraduate Programs

Graduate Programs

Masters Programs

[Arts in Art Education](#)
[Criminal Justice](#)
[Music, Music Education](#)
[Science in Computer Information Systems](#)
[Science in Health Communication](#)
[Science in \(Specialty\) Management](#)
[Banking & Financial Services Management](#)
[Business Continuity, Security & Risk Management](#)
[International Marketing Management](#)
[Insurance Management](#)
[Project Management](#)
[Science in Occupational Therapy](#)

Doctoral Programs

[Musical Arts, Music Education](#)
[Occupational Therapy](#)
[Physical Therapy](#)

Certificate Programs

Individual Courses

Professional Courses

[BU Online Home](#) » [Programs](#) » [Graduate](#) » [MSM](#) » [Emergency Management](#)

Master of Science in (Specialty) Management Specialization in Business Continuity, Security & Risk Management

[Overview](#)
[Courses](#)
[Request Info](#)

Overview

This MS specialization in Business Continuity, Security & Risk Management builds on four-course curriculum of the Boston University Online Graduate Certificate in Risk Management & Organizational Continuity).

Designed to provide the tools and concepts necessary to plan for, prevent, and—when needed—successfully respond to disruptions in business operations, this concentration provides a review of important issues relating to business continuity, security, information and materials management, as well as risk management from a planning, operations, and response perspective. Topics presented include incident response and disaster recovery, compliance issues, and systemwide risk analysis. Business continuity is viewed organizationally to include all company operations, and addresses information, computer systems, infrastructure, personnel, and supply chain, as well as emergencies emanating from man-made and natural disasters.

With appropriate advanced planning, you can use degree electives from your online Master of Science in Business Continuity, Security & Risk Management to satisfy up to two required courses in an Administrative Sciences [graduate certificate program](#)—leaving only two additional courses to be completed in order to receive a graduate-level certificate.

Welcome

Company

[About Us](#)
[Partners](#)
[Client Stories](#)
[Why Choose Us?](#)
[Contact North River Solutions](#)



North River Solutions, Inc.

We help build highly resilient organizations that meet the performance demands of today's 24x7 world economy. North River Solutions is a diverse company with a worldwide presence. Every member of our executive team is a former CEO or President of a successful company. We know how to get things done – from planning to implementation. North River expertise includes: auditing, business continuity planning, compliance and regulatory management, operational resiliency, sales management, data center operations, engineering, executive training, storage management, and marketing. Our experience spans many industries including:

- **Financial Services**
- **Healthcare & Medical Imaging**
- **Energy Exploration**
- **Transportation (Air, Sea, Road, Rail)**
- **Food Services**
- **Tourism and Travel**
- **Supply Chain Management**
- **Retail Operations**
- **General Software Startup**

Quicklinks

[Resiliency1 Index](#)

[ICOR](#)

[Training Schedule](#)

[News](#)

[Contact Us](#)

Download Library



Business Impact Analysis: Methods and Techniques that Work!

Kathleen Lucey
EMC Corporation
kathleen.lucey@emc.com

Part 1: Getting Ready!

Getting Started on a BIA

- Educate: begin with yourself...
- Assess the level of firm awareness/knowledge
- Find a C-level champion/sponsor
- Develop your arguments
- Develop your presentation

Educate: How much do YOU know?

- Readings, conferences, websites:
 - Articles at www.continuitycentral.com
 - Articles at www.continuitycompliance.org
 - BCI GPG at <http://www.thebci.org/gpg.htm>
 - Various BIA classes (online and in-class)

- BIA =
 - Impact analysis of an interruption
 - C.R.R.A.
 - Risk Assessment

Firm awareness/knowledge?

- Past experience: BIA/BC Plan
- Successes....or failures?
- Stable or constantly changing?
- Risk appetite?
- Audit awareness

C-level champion/sponsor?

- Look to CFO, CIO, revenue-generating business unit
- Someone who can carry your message to her/his peers
- Stay away from insurance or other cost centers
- Audit awareness?

Develop your arguments

- Analysis of BIA information yields:
 - Mitigation strategies
 - Continuity strategies
- These strategies become the BC Plan
- So how do you get to a GOOD plan without a BIA?

Develop your presentation

- Very brief intro – 2 minutes (2 slides)
- Define the BIA benefits in ONE slide
- Propose 3 alternatives:
 - Do nothing
 - Do a pilot
 - Do it all at once

Close the deal

- Demonstrate the inadequacies of #1 and #3
- Demonstrate the strengths of #2: pilot
- Do not go into the details: that comes later.
- Finish in 10 minutes

Don't sweat the details

- Initial management buy-in allows you to go through the normal project funding process
- Costs, funding, strategy
- Project Plan
- Count on some time to get specific approval

Business Impact Analysis: Methods and Techniques that Work!

Mark Carroll

Boston University

MarkCarroll100@aol.com



Part 2: Running a Successful BIA

Know the deal you have closed

- Key project phase of an overall program
- BIA is cornerstone of program
 - Pilot phase is key proof-of-concept or primary phase of BIA project
 - Pilot provides early success/deliverable(s)
- BIA effort should be properly structured as a project
 - Timetable, Milestones, Deliverables
 - Leverage existing organizational project methodology (e.g., Waterfall, AGILE, LEAN, etc.)
- BIA is ongoing process
 - Maintenance (Annually?)

Pilot Phase

- Leverage C Level support into the C (-) level and beyond
- Define pilot process and timetable (publish!)
- Define holistic framework or approach
- Determine scalability, synergies, validation across function or site landscape
- Don't attempt to boil the ocean either with breadth or depth
 - BIA process can evolve/develop over time
 - Pilot functions should be achievable/representative

BIA Considerations

- Identify key impact dimensions *
 - Regulatory/Statutory (both direct and indirect)
 - Contractual (both customer and vendor)
 - Certifications/Validations
 - Current (e.g., ISO 900x) and planned (e.g., BS25999)
 - Business Operations
 - Financial Impact
 - Supply Chain Factors
 - Future business considerations (product/market)

* With Special consideration for Reputation/Brand

BIA Process: The *What*

- Essentially a data collection and validation effort
 - Questionnaire-based (but not a survey)
 - Objective assessment/review of all processes
 - Consistent domain of questions, inputs across all functions
 - Consistent / standard deliverable (output)
- Must include inventory of all functions/processes
 - Critical functions cannot be assumed so, but are determined by process
- Universal yardstick is dollars (\$) lost
 - Not always understood or agreed (but make it so)
 - May require some assumptions or translation for certain functions
 - Not dollars delayed (except as loss component)

OK, so what about Systems?

- Not a factor at this stage (at least not usually)
 - Typically (strictly?) a supporting activity (not unlike HR, Facilities, etc.)
- But, there could be special considerations in INFOSEC realm
 - Intellectual Property (e.g., Research, Manufacturing)
 - Privacy (e.g., Healthcare, Financial Services)
 - Case can be made for a Personal Impact Assessment (PIA)

Results/Deliverables *

- Defined process for executing a BIA
 - Immature at this stage; needs to evolve and grow over time
 - Heuristic process with improvements from learnings incorporated
- Completed BIA process for Pilot functions (something in the can!)
 - Basis for plan development
 - Baseline for other functions as BIA process rolled out
- Project plan for full BIA rollout
 - Timings from pilot process

* All with Senior Management's blessing

Business Impact Analysis: Methods and Techniques that Work!

Don Byrne
North River Solutions
dbyrne@NorthRiverSolutions.com

Part 3: Using the Information

Before Presenting The Report:

- Reviewed and verify your findings
- That the final report contains no surprises
- That you have summarized the information for management
- Be as graphical as you can
- Be as clear as you can!

Presenting Your Information

Set Priorities

Prioritization of Processes by Recovery Time Objective (in Hours)

Number of Processes within Tier

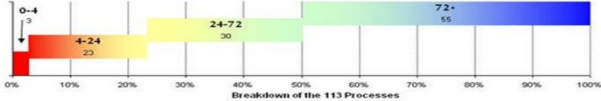

Prioritization of Divisions based on Aggregate Process Recovery Time Objectives

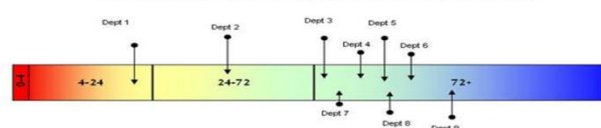

Disaster Recovery – Tape Recovery Times

Drive Type	Media Size	WORM Capable*	Drive Format Standard	Media Native Capacity GB	Transfer Speed in Mbytes/sec	Transfer Speed per Drive Gbytes/hr	Hours for transfer of 1 Terabyte per Drive
DAT	4mm	NO	DDS-4	20.0	3.00	10.8	92.6
DAT	4mm	NO	DAT-72	36.0	3.58	12.6	79.5
AIT	8mm	YES	AIT-5	400.0	24.00	86.4	11.6
SAIT-1	1/2in.	YES	SAIT-1	500.0	30.00	108.0	9.3
DLT	1/2in.	NO	DLT18000	40.0	6.00	21.6	48.3
DLT	1/2in.	NO	DLT1	40.0	3.00	10.8	92.6
DLT VS	1/2in.	NO	DLT VS160	80.0	8.00	28.8	34.7
SDLT	1/2in.	NO	SDLT320	160.0	16.00	57.6	17.4
SDLT	1/2in.	YES	SDLT600	300.0	36.00	129.6	7.7
LTO	1/2in.	NO	Ultrium	100.0	20.00	72.0	13.9
LTO	1/2in.	NO	Ultrium-2	200.0	35.00	126.0	7.9
LTO	1/2in.	YES	Ultrium-3	400.0	68.00	244.8	4.1
IBM	1/2in.	NO	3590E	40.0	14.00	50.4	19.8
IBM	1/2in.	NO	3590H	60.0	14.00	50.4	19.8
IBM	1/2in.	YES	3592	40.0	40.00	144.0	6.9
IBM	1/2in.	YES	TS1120	700.0	104.00	374.4	2.7
STK	1/2in.	YES	9940 C	40	30.00	108.0	9.3
STK	1/2in.	YES	9940 B	200	30.00	108.0	9.3
STK	1/2in.	YES	T10000	500	40.00	144.0	6.9



Cost Vs Recovery Time

Continuous Availability

Hot Solution

Hot Solution

Hot Solution

Hot Solution

Hot Solution

Hot Solution

Hot Solution

Hot Solution

Hot Solution

Hot Solution

Hot Solution

Hot Solution

Rapid Recovery

Warm Solution

Warm Solution

Warm Solution

Warm Solution

Warm Solution

Warm Solution

Warm Solution

Warm Solution

Recovery

Cold Solution

Cold Solution

Cold Solution

Cold Solution

Cold Solution

Recovery Time

Identified Critical Processes

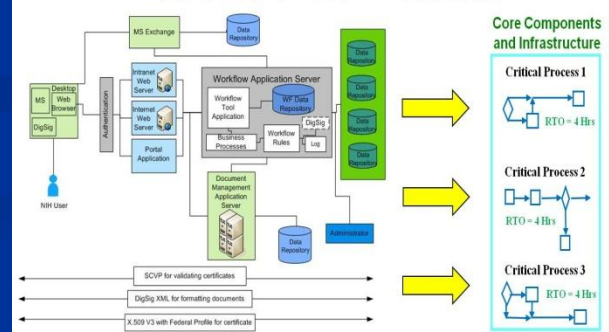

Don't Get Carried Away!

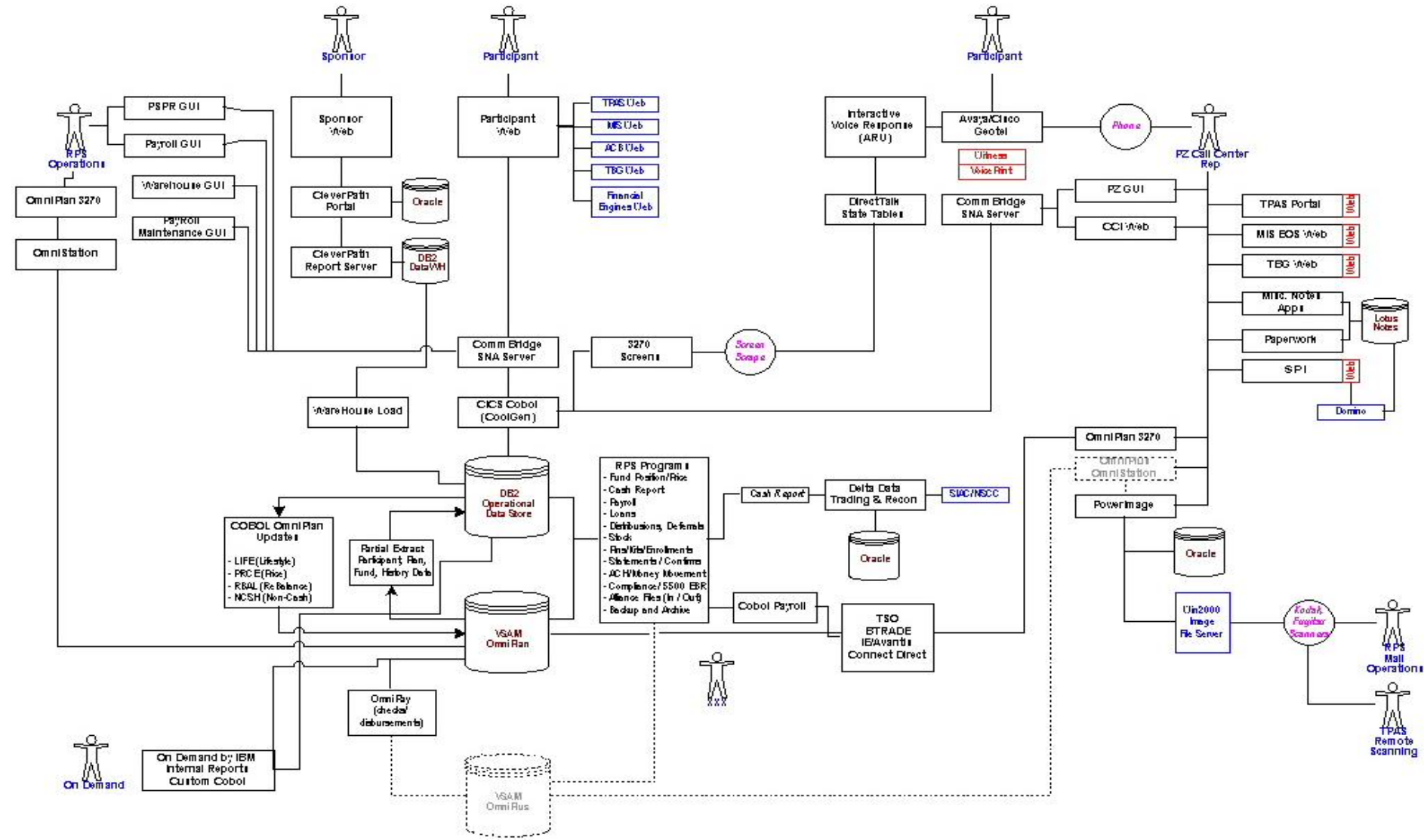

Be Careful Of Terminology!

RTO and RPO

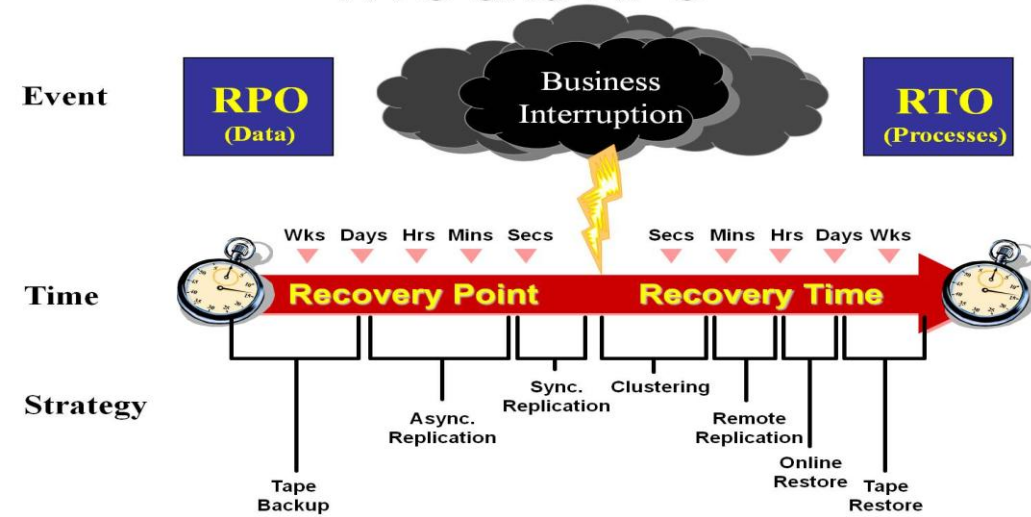

MTPod

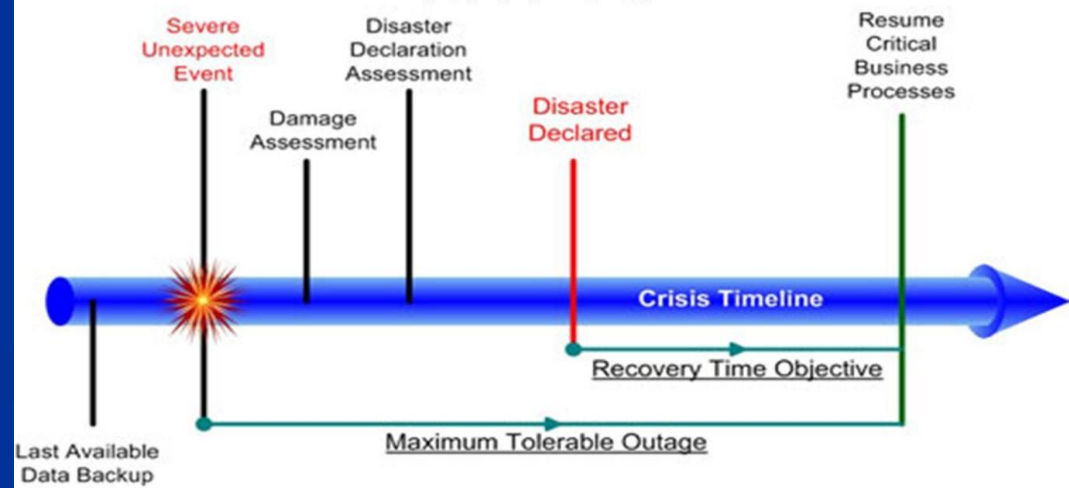

BIA = A Business MRI Of Your Firm

Workflow

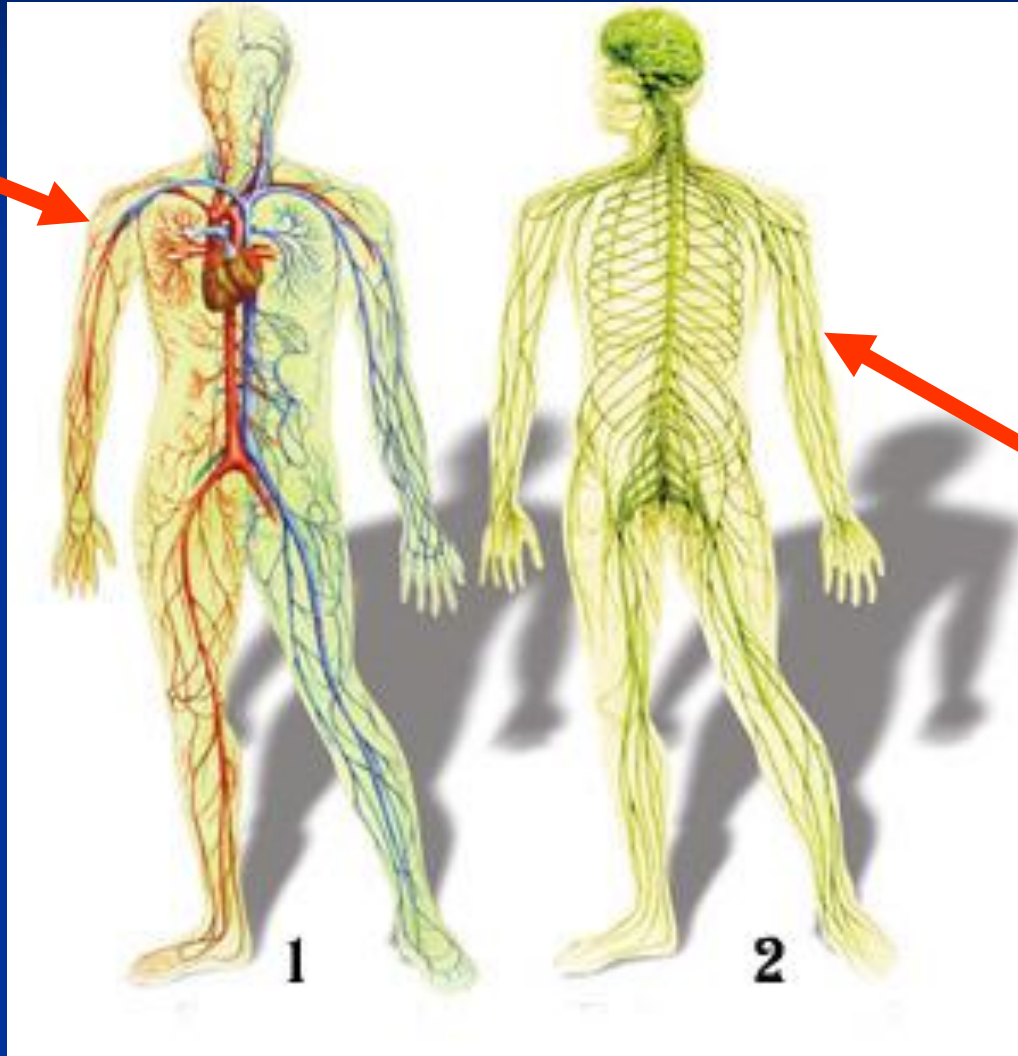

Infrastructure



Another Perspective

- Suggestion: Don't present your findings as part of your Business Continuity Plan!

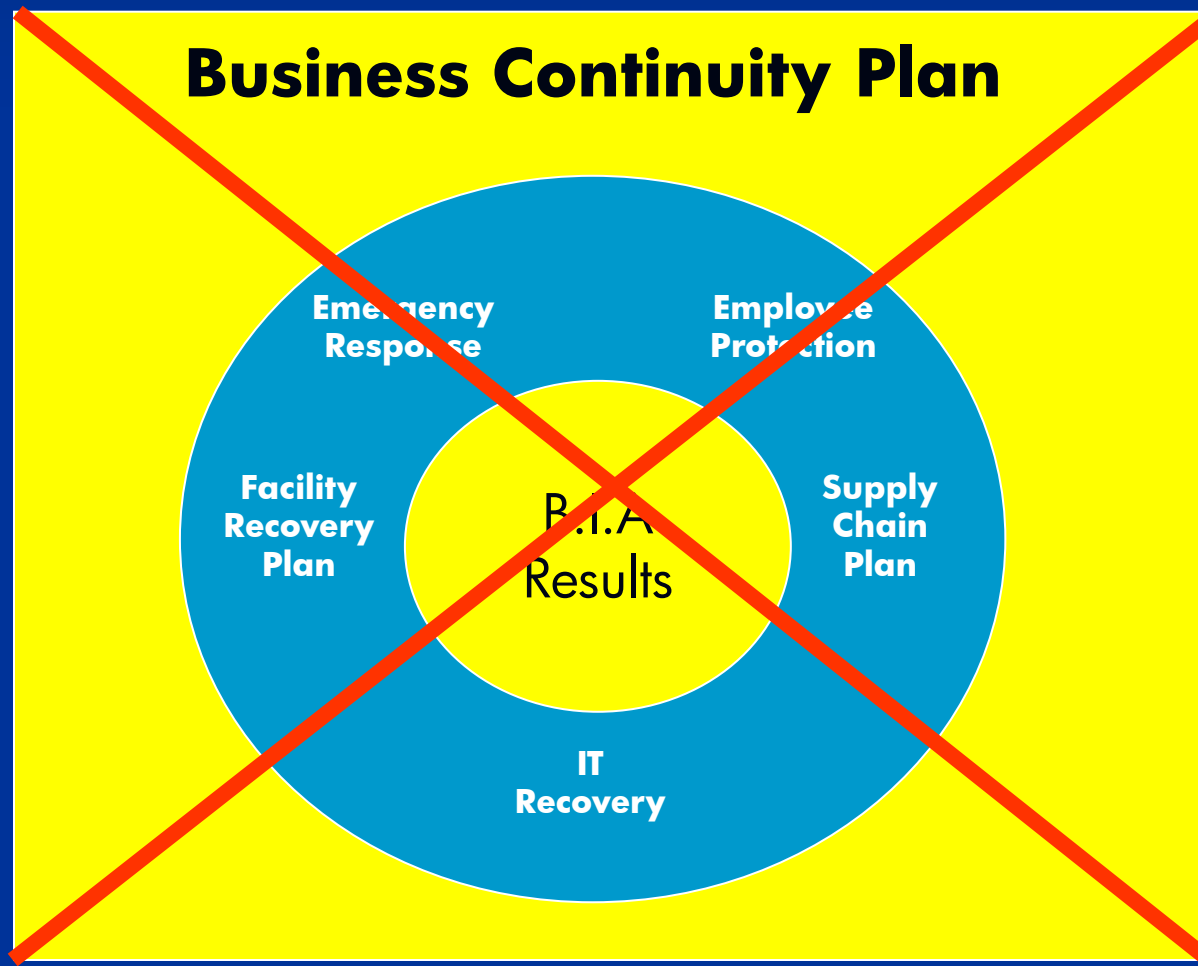

Other Ways To Use the Information

1. Assist with *capacity capabilities* for growth and long-term planning (IT, Supply Chain, HR, Facilities, etc.)
2. Corporate dependencies on outside contracts that merit greater attention.
3. Protection and Spoliation of vital records
4. Potential regulatory violations
5. Safety and Security considerations
6. “Downsizing” and “right-sizing” activities

Closing Comments

- Present meaningful, verified facts
- That have value to management (i.e., new information)
- In a clear and graphical manner
- Using plain language (i.e., no *buzz words*)
- So that *mere mortals can understand the findings*

And don't limit yourself to just BCP Planning issues

Thanks To Our Panelists

Kathleen Lucey

kathleen.lucey@emc.com

Mark Carroll

MarkCarroll100@aol.com

Don Byrne

Dbyrne@NorthRiverSolutions.com

Now - It's Your Turn



Thank You!

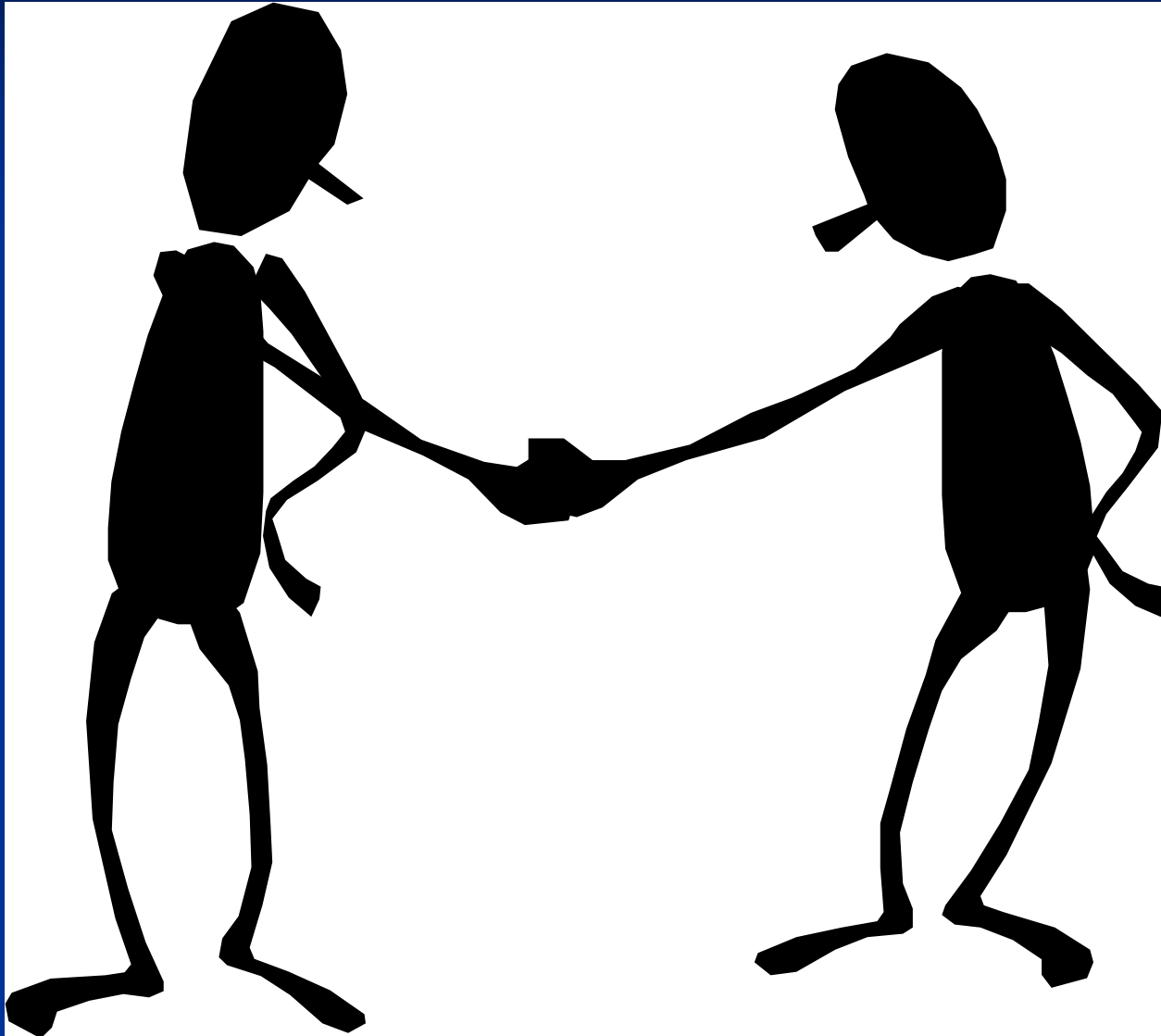

Final Words

Our Hosts



Our Sponsors



Our Panelists



Questions ,Comments, Suggestions

webinars@metrix411.com

Business Impact Analysis: Methods and Techniques that Work!

